



Topic: Project Networks

Time: 45 mins

Marks:

/45 marks

No Calculator Allowed

Question One: [4, 4: 8 marks]

Calculate the minimum completion time and show the critical path on each of the project networks below.

a)

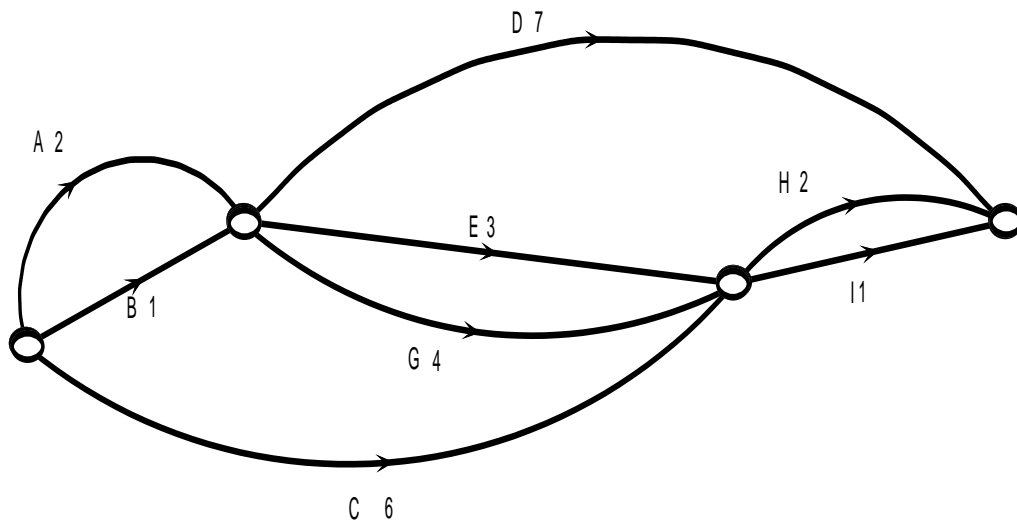

b)

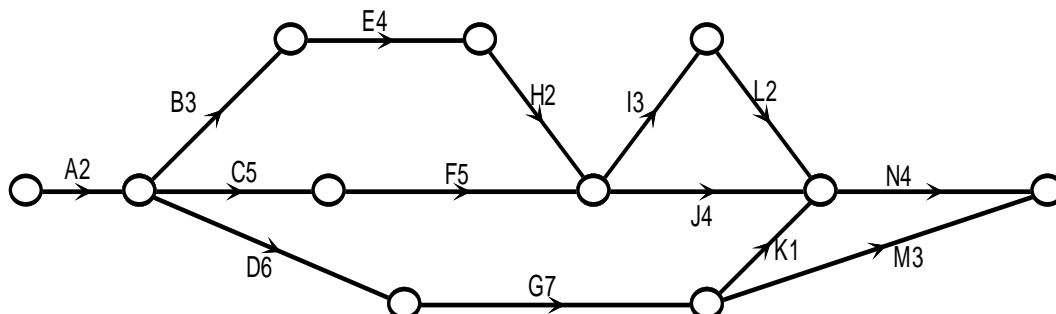

Mathematics General Unit 4
(Applications Course in WA)

Question Two: [3, 4, 2, 2: 11 marks]

Consider the following table:

Activity	Immediate Predecessors	Length of Time (Days)
A	-	5
B	A	3
C	A	6
D	A	8
E	B	3
F	B	5
G	E, C, D	2
H	E, C, D	6
I	F, G	3
J	H, I	4

- a) Draw the network for the project described above.

Mathematics General Unit 4
(Applications Course in WA)

- b) State the minimum completion time and the critical path.
- c) What is the float time on activity E?
- d) What is the latest time Activity G can start without delaying the projecting?

Mathematics General Unit 4
(Applications Course in WA)

Question Three: [3, 2, 2, 2, 2, 2: 13 marks]

Leslie Knope of the Parks Department has the following process to follow in order to build a new park.

Job	Immediate Predecessor	Excepted time
Acquire land	-	2 weeks
Rezone land	Acquire land	1 week
Apply for Permits	Acquire land	10 days
Environmental Impact Report	Acquire land	8 days
Finalize Budget	Acquire land	6 days
Build Playground	Finalize budget and Rezone Land	4 weeks
Landscaping	Environmental Impact Report and Build Playground	1 week
Safety inspection	Build Playground	2 days
Private Trial	Apply for Permits, Safety inspection and Landscaping	1 day
Official Opening	Private Trial	1 day

- a) Construct a project network to represent the process of building a new park.

Mathematics General Unit 4
(Applications Course in WA)

- b) How long does it take to build a new park?
- c) What are the critical activities?
- d) What is the longest delay possible in the application for permits before it delays the completion of the project?
- e) If the safety inspection takes a week does this impact on the completion time of the project?

The parks department is extremely busy and they only have one person available to work on this project. Each task requires a worker from the parks department to be working on that activity for the entire time mentioned in the table.

- f) How long does it take to complete if there is only one person available to work on the project?

Question Four: [4, 2, 2, 2, 3: 13 marks]

Consider the following project network for baking a cake.

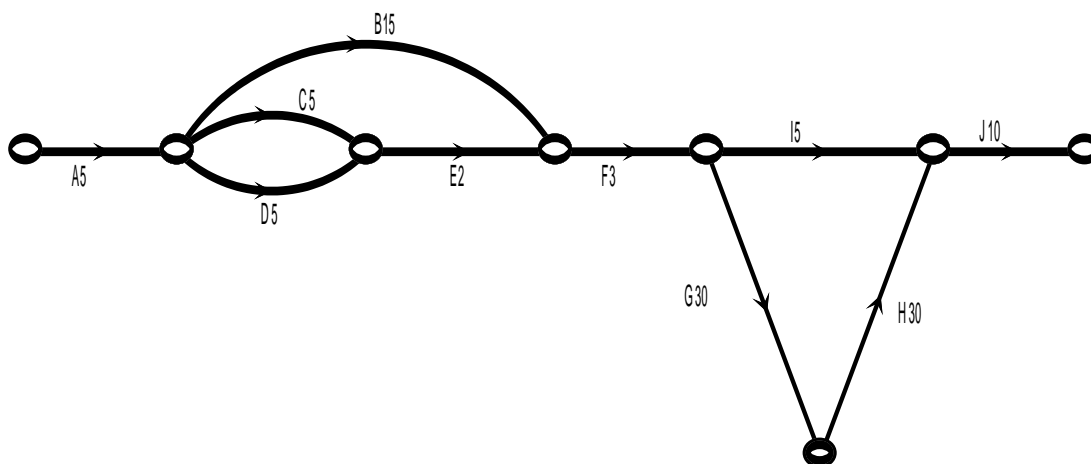

a) Complete the table to describe the activities shown in the project network.

Letter	Activity	Immediate Predecessor	Time (mins)
A	Find recipe		
B	Preheat oven		
C	Add and Mix wet ingredients		
D	Add and mix dry ingredients		
E	Combine wet and dry ingredients and mix together		
F	Pour into oven proof dish and place in oven		
G	Bake in oven		
H	Remove from oven and allow to cool		
I	Make icing		
J	Apply icing		

Mathematics General Unit 4
(Applications Course in WA)

- b) What is the minimum completion time for baking a cake?

- c) What is the critical path?

- d) What is the float time allowed during the icing making?

- e) If Julie uses all the float time allowed for making the icing and finishes this activity at exactly 3:05 pm, what time did she begin this project?



education equals

Topic: Project Networks SOLUTIONS

Time: 45 mins

Marks: /45 marks

No calculator allowed

Question One: [4, 4: 8 marks]

Calculate the minimum completion time and show the critical path on each of the project networks below.

a)

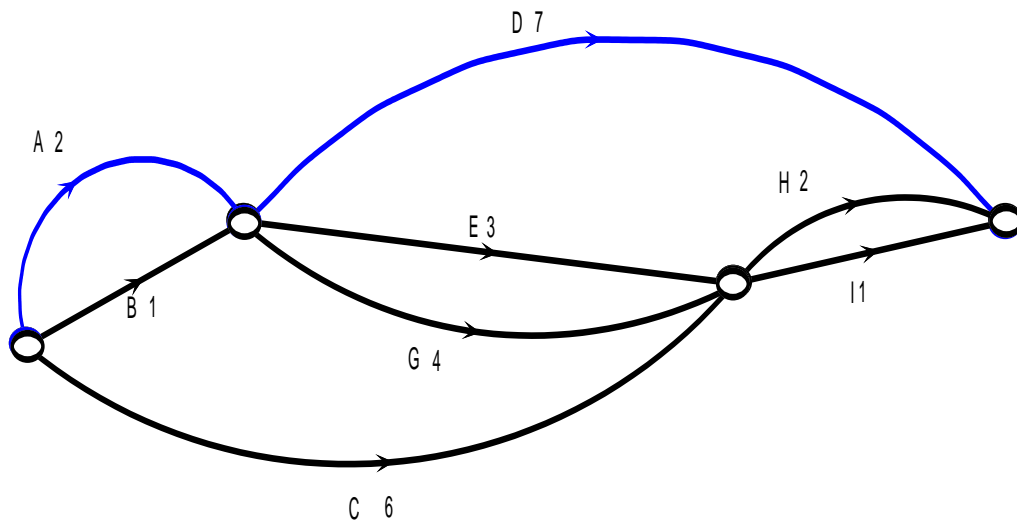

Critical path $A - D$ time: 9 units



b)

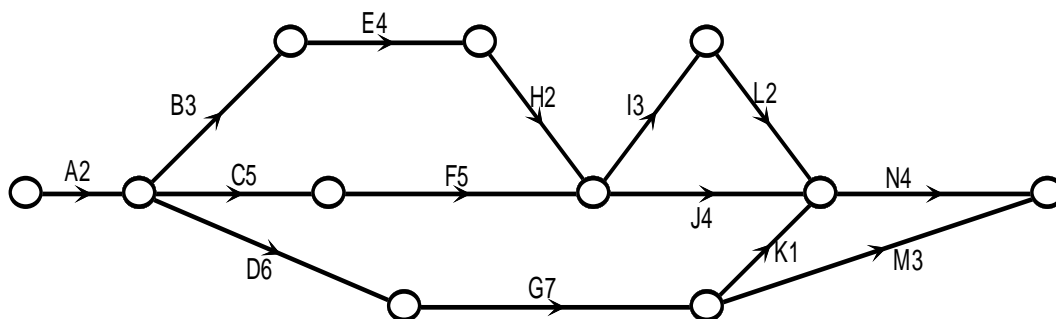

Critical path $A - C - F - I - L - N$ time: 21 units



Question Two: [3, 4, 2, 2: 11 marks]

Consider the following table:

Activity	Immediate Predecessors	Length of Time (Days)
A	-	5
B	A	3
C	A	6
D	A	8
E	B	3
F	B	5
G	E, C, D	2
H	E, C, D	6
I	F, G	3
J	H, I	4

a) Draw the network for the project described above.

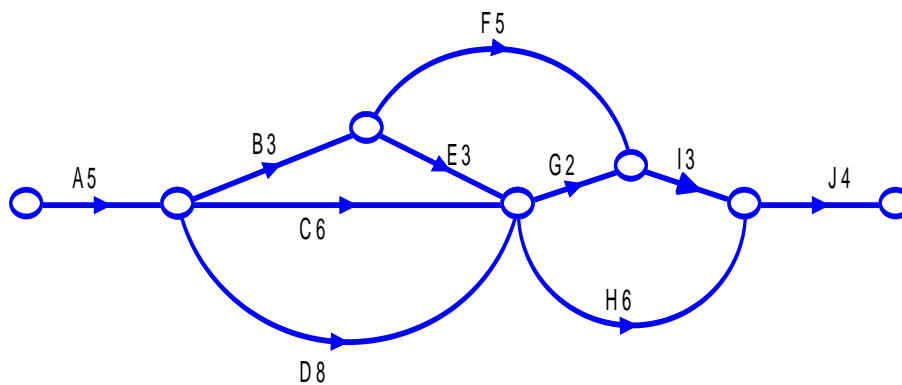

network ✓

arrows ✓

labels ✓

Mathematics General Unit 4
(Applications Course in WA)

b) State the minimum completion time and the critical path.

23 days ✓ ✓
A – D – H – J ✓ ✓

c) What is the float time on activity E?

2 days float time ✓ ✓

d) What is the latest time Activity G can start without delaying the projecting?

Latest day activity G could start would be day 14. ✓ ✓

Question Three: [3, 2, 2, 2, 2, 2: 13 marks]

Leslie Knope of the Parks Department has the following process to follow in order to build a new park.

	Job	Immediate Predecessor	Excepted time
A	Acquire land	-	2 weeks
B	Rezone land	Acquire land	1 week
C	Apply for Permits	Acquire land	10 days
D	Environmental Impact Report	Acquire land	8 days
E	Finalize Budget	Acquire land	6 days
F	Build Playground	Finalize budget and Rezone Land	4 weeks
G	Landscaping	Environmental Impact Report and Build Playground	1 week
H	Safety inspection	Build Playground	2 days
I	Private Trial	Apply for Permits, Safety inspection and Landscaping	1 day
J	Official Opening	Private Trial	1 day

a) Construct a project network to represent the process of building a new park.

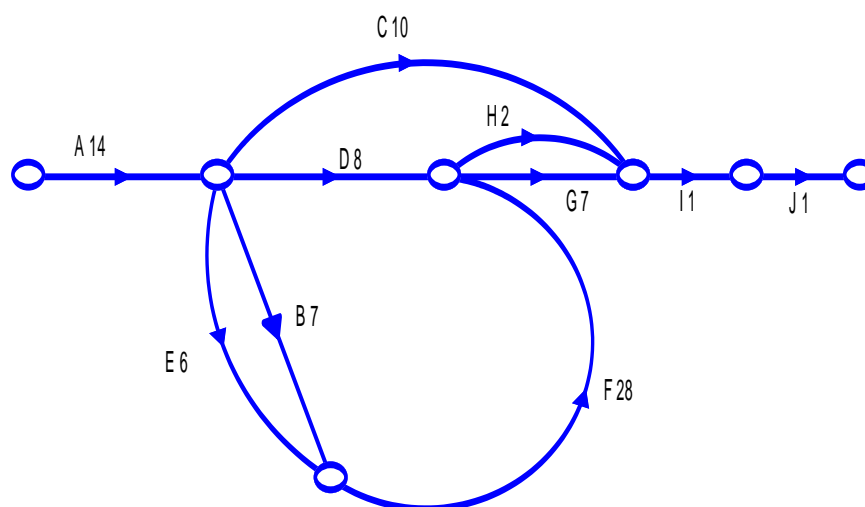

- network ✓
- arrows ✓
- labels ✓

Mathematics General Unit 4
(Applications Course in WA)

b) How long does it take to build a new park?

58 days ✓ ✓

c) What are the critical activities?

Acquire land, Rezone land, Build playground, Landscaping, Private Trial and Official Opening.

✓ ✓

d) What is the longest delay possible in the application for permits before it delays the completion of the project?

32 days ✓ ✓

e) If the safety inspection takes a week does this impact on the completion time of the project?

No there is exactly 5 days float time on this activity so any longer than a week and it will delay the completion but 1 week is fine.

✓ ✓

The parks department is extremely busy and they only have one person available to work on this project. Each task requires a worker from the parks department to be working on that activity for the entire time mentioned in the table.

f) How long does it take to complete if there is only one person available to work on the project?

$58 + 10 + 8 + 2 + 6 = 84$ days ✓ ✓

Question Four: [4, 2, 2, 2, 3: 13 marks]

Consider the following project network for baking a cake.

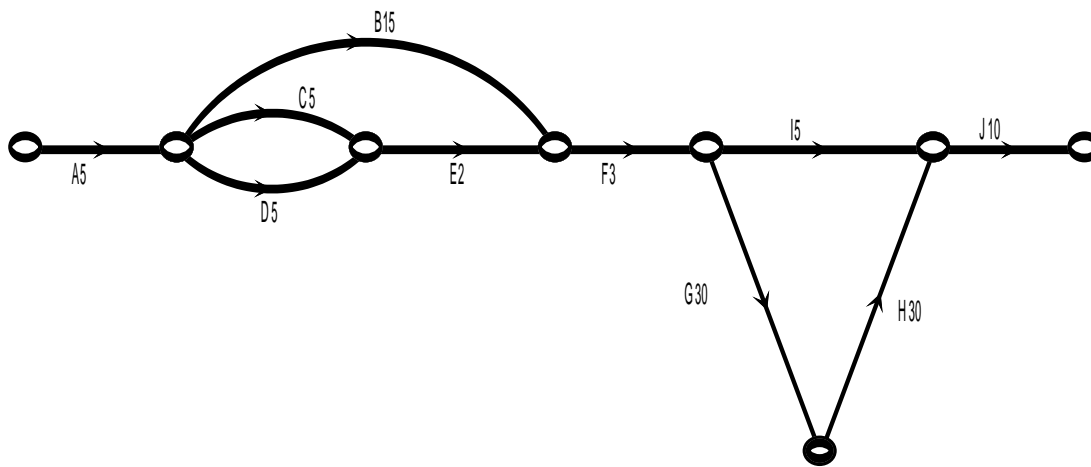

a) Complete the table to describe the activities shown in the project network.

Letter	Activity	Immediate Predecessor	Time (mins)
A	Find recipe	None	5
B	Preheat oven	A	15
C	Add and Mix wet ingredients	A	5
D	Add and mix dry ingredients	A	5
E	Combine wet and dry ingredients and mix together	C and D	2
F	Pour into oven proof dish and place in oven	B and E	3
G	Bake in oven	F	30
H	Remove from oven and allow to cool	G	30
I	Make icing	F	5
J	Apply icing	I and H	10



Mathematics General Unit 4
(Applications Course in WA)

b) What is the minimum completion time for baking a cake?

93 mins = 1 hour 33 mins ✓✓

c) What is the critical path?

A - B - F - G - H - J ✓✓

d) What is the float time allowed during the icing making?

55 mins ✓✓

e) If Julie uses all the float time allowed for making the icing and finishes this activity at exactly 3:05 pm, what time did she begin this project?

